

CLEANING AND STORAGE

- To clean your fan, first turn it OFF and UNPLUG the unit.
- Use a soft cloth to wipe the housing. DO NOT use water or any other chemical solution or cleaner. DO NOT soak or immerse the fan in water or liquid.
- DO NOT ATTEMPT TO TAKE THE FAN APART.
- Store in a dry place away from excessive heat and direct sunlight.
- Regular cleaning will ensure optimum performance and appearance of the fan.
- DO NOT kink the power cord when storing or while in use.

TROUBLESHOOTING

Problem	■ Fan does not operate
Possible Cause	■ Battery charge is insufficient to power the unit (when operating using battery power) ■ Charger plug is not fully inserted into the wall
Solution	■ Make sure the charger plug is fully inserted into the wall outlet and charge the fan's battery until the red light above the power button on the fan changes to blue

REMOTE BATTERY STATEMENT

- Use type CR2025 batteries only.
- Install only new batteries of the same type in your product.
- Failure to insert batteries in the correct polarity, as indicated in the battery compartment, may shorten the life of the batteries or cause batteries to leak.
- Do not mix old and new batteries.
- Do not mix Alkaline, Standard (Carbon-Zinc) or Rechargeable (Nickel Cadmium) or (Nickel Metal Hydride) batteries.
- Danger of explosion if battery is incorrectly replaced.
- Batteries should be recycled or disposed of as per state or local guidelines.

REMOTE CONTROL BATTERY REPLACEMENT

- On the back of the remote, press the release button on the bottom right hand side. This will allow the tray containing the battery to be released. Release the tray by squeezing the small lip and pulling down the tab at the bottom of the remote (Fig. 2).

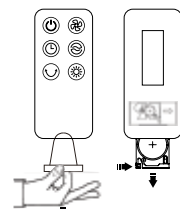

Fig. 1 Fig. 2

- Replace the battery with one new CR2025 button battery. Important: Install only new batteries of the same type in your

product. Failure to insert batteries in the correct polarity, as indicated in the battery compartment, may shorten the life of the batteries or cause batteries to leak. Do not mix old and new batteries. Do not mix Alkaline, Standard (Carbon-Zinc) or Rechargeable (Nickel Cadmium) or (Nickel Metal Hydride) batteries. Danger of explosion if battery is incorrectly replaced. DO NOT DISPOSE OF BATTERY IN FIRE, BATTERY MAY EXPLODE OR LEAK

- This product contains a button cell battery. If swallowed, it could cause severe injury or death in just 2 hours. Seek medical attention immediately.

HAVE A PROBLEM? PLEASE CONTACT CUSTOMER SERVICE.

Should you have any questions or comments please contact us at: customerservice@blackstoneltd.com or by phone at 1-888-525-7969

WARRANTY: This fan includes a one (1) year warranty, which covers manufacturer defects and workmanship under normal use. Warranty is offered only to the original purchaser. Proof of purchase is required. Proof of purchase constitutes a dated sales receipt. This warranty is void if the fan(s) have been subject to abuse such as: being dropped which could result in damage to the fan cabinets, motors, fan controls, etc. immersion in or exposure to water, exposure to excessive heat, outdoor usage, any use other than household use, disassembly, repair or alteration by anyone other than an authorized service provider, use on improper voltage or current, or any use contrary to the user instructions. Batteries and battery life are not covered in this warranty. DO NOT attempt to repair any electrical or mechanical functions of this product; doing so will void this warranty and could lead to injury.

FCC STATEMENT OF COMPLIANCE

This device complies with part 15 of the FCC Rules. Operation is subject to the following two conditions: (1) this device may not cause interference, and (2) this device must accept any interference, including interference that may cause undesired operation. Note: This equipment has been tested and found to comply with the limits for a Class B digital device, pursuant to Part 15 of the FCC rules and Industry Canada ICES-003. These limits are designed to provide reasonable protection against harmful interference when the equipment is operated in a residential installation. This equipment generates uses and can radiate radio frequency energy and, if not installed and used in accordance with the instructions, may cause harmful interference to radio communications. However, there is no guarantee that interference will not occur in a particular installation. If this equipment does cause harmful interference to radio or

television reception, which can be determined by turning the equipment off and on, the user is encouraged to try to correct the interference by one or more of the following measures:

- Reorient or relocate the receiving antenna.
- Increase the separation between the equipment and receiver.
- Connect the equipment into an outlet on a circuit different from that to which the receiver is connected.
- Consult the dealer or an experienced radio/TV technician for help.

Note: This device complies with part 15 of the FCC rules and Industry Canada ICES-003. Operation is subject to the following two conditions: (1) This device may not cause harmful interference, and (2) this device must accept any interference received, including interference that may cause undesired operation.



BLACKSTONE
CASCADE
CAPRI

OSCILLATING FAN INSTRUCTION MANUAL

MODEL: CCFT-P-22, CCFT-B-22, CCFT-CP-22, CCFT-C-22, CCFT-SG-22, CCFT-S-22

FAN
VOLTAGE: 12V
WATTAGE: 20 W

CHARGER INPUT
VOLTAGE: 120V
FREQUENCY: 60 Hz,
1.0 A Max

CHARGER OUTPUT
12V, 3.0A

BATTERY: 4,000 mAh

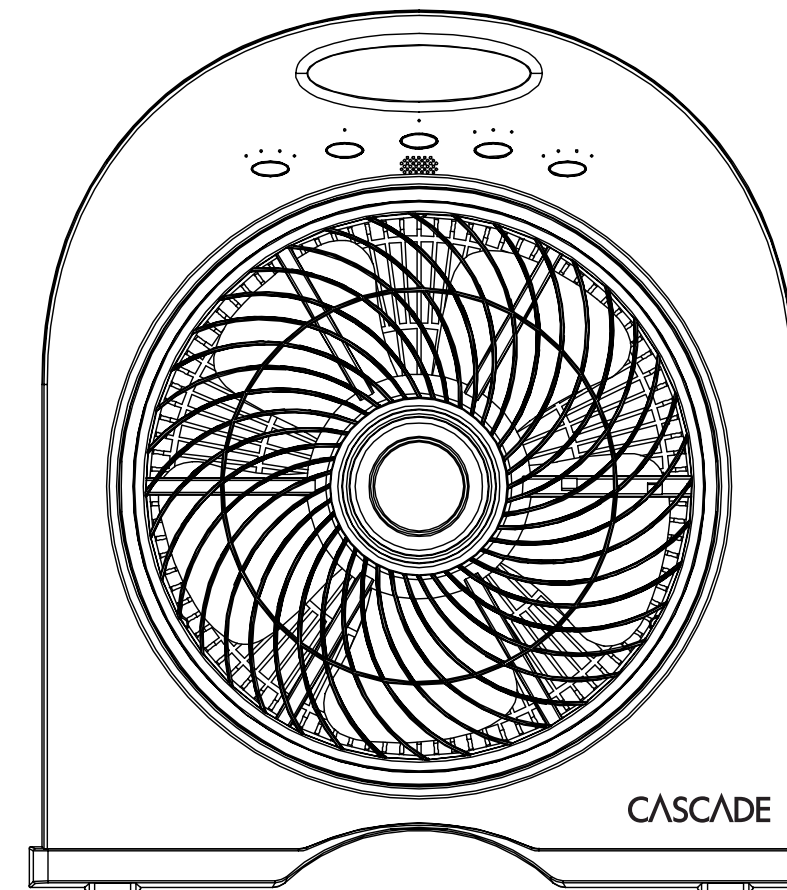

**IMPORTANT, RETAIN FOR FUTURE REFERENCE:
READ CAREFULLY | FOR HOUSEHOLD USE ONLY
Use Only With provided 12V charger.**

This product contains a button battery. If swallowed, it could cause severe injury or death in just 2 hours. Seek medical attention immediately.

Blackstone International Ltd. and other trademarks are the property of the respective owners. All other brand names and logos are registered trademarks of their respective owners.

MADE IN CHINA | Distributed by: Blackstone International, Ltd.

PLEASE READ AND SAVE THESE INSTRUCTIONS WHEN USING ELECTRICAL APPLIANCES, BASIC PRECAUTIONS SHOULD ALWAYS BE FOLLOWED TO REDUCE THE RISK OF FIRE, ELECTRIC SHOCK AND INJURY TO PERSON OR PROPERTY, INCLUDING THE FOLLOWING:

- Read all instructions before using this product.
- Use this fan only as described in this manual. Any other use not recommended by the manufacturer may cause fire, electrical shock or injury to person or property and may void the warranty.
- Always unplug unit before assembly, disassembly or cleaning.
- Always unplug unit when not in use, when moving from one location to another and before cleaning.
- To disconnect, grasp the plug and pull it from the wall outlet. DO NOT unplug by pulling on cord.
- The use of attachments is not recommended nor sold by the manufacturer and may cause hazards.
- Avoid contact with moving parts.
- DO NOT operate any fan with a damaged cord or plug, after a malfunction, or if dropped or damaged in any manner.
- DO NOT operate the fan in the presence of explosive and/or flammable fumes.
- DO NOT place the fan or any parts near an open flame, cooking or other heating appliances.
- Extreme caution is necessary when fan is used by or near children and whenever the fan is left operating and unattended.
- This product is intended for household use only and not for commercial or industrial use.
- DO NOT use outdoors.
- Always use on a dry, level surface.

- DO NOT operate if the fan housing is removed or damaged.
- A loose fit between the AC outlet and plug may cause overheating of the plug; consult a qualified electrician.
- DO NOT run cord under carpeting. DO NOT cover cord with throw rugs, runners, or the like. Arrange cord away from traffic areas and where it will not be tripped over.
- DO NOT connect the fan to any power sources other than a 120V alternating current polarized outlet.
- WARNING: To reduce the risk of electric shock, DO NOT use this fan with any solid-state speed control and DO NOT insert finger or any object into grill.
- WARNING: KEEP BATTERIES OUT OF REACH OF CHILDREN
- Swallowing may lead to serious injury in as little as 2 hours or death, due to chemical burns and potential perforation of the esophagus.
- If you suspect your child has swallowed or inserted in their body a button battery, immediately seek urgent medical assistance.
- Examine devices and make sure the battery compartment is correctly secured, e.g. that the screw or other mechanical fastener is tightened. Do not use if compartment is not secure.
- Dispose of used button batteries immediately and safely. Flat batteries can still be dangerous.
- Tell others about the risk associated with button batteries and how to keep children safe.

NOTICE

1. WARNING: TO REDUCE THE RISK OF FIRE OR ELECTRIC SHOCK, DO NOT USE THIS FAN WITH ANY SOLID-STATE SPEED CONTROL DEVICE.
2. Do not operate any fan with a damaged cord or plug. Discard fan or return to an authorized service facility for examination and/or repair.
3. Do not run cord under carpeting. Do not cover cord with throw rugs, runners, or similar coverings. Do not route cord under furniture or appliances. Arrange cord away from traffic area and where it will not be tripped over.



WARNING: Chemical Burn Hazard. Keep batteries away from children. This product contains a lithium button/coin cell battery. If a new or used lithium button/coin cell battery is swallowed or enters the body, it can cause severe internal burns and can lead to death in as little as 2 hours. Always completely secure the battery compartment. If the battery compartment does not close securely, stop using the product, remove the batteries, and keep it away from children. If you think batteries might have been swallowed or placed inside any part of the body, seek immediate medical attention. The cells shall be disposed of properly, including keeping them away from children. Even used cells may cause injury.

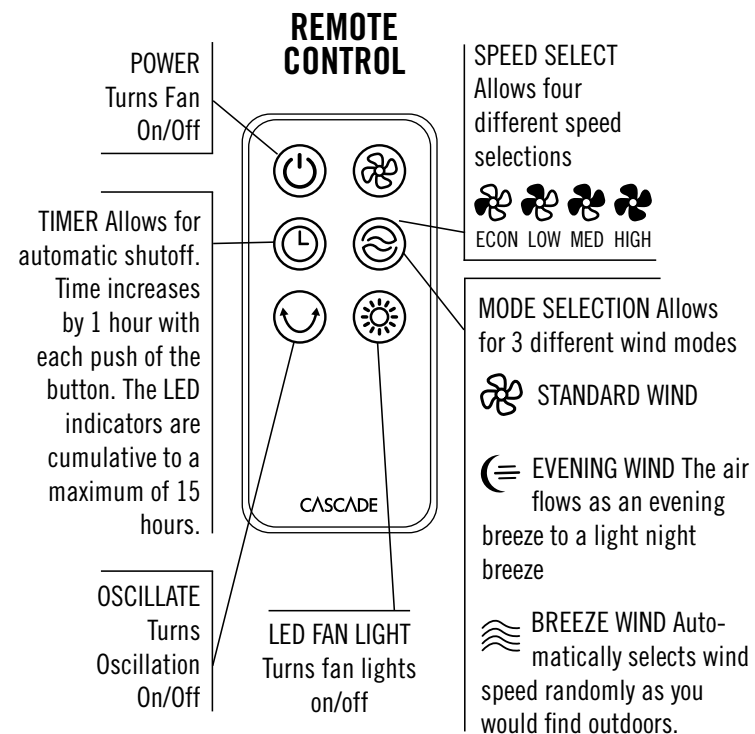

EXPLANATION OF MODES

- Standard Wind** The Standard Wind mode is simply the ECON, LOW, MED, HIGH speed settings
- Evening Wind** The air flows as an evening breeze to a light night breeze and are detailed as follows:
 - ECON Evening Wind** The air flow remains at ECON
 - LOW Evening Wind** The air flow begins at LOW, after half an hour it will drop down to ECON
 - MED Evening Wind** The air flow begins at MED, after half an hour it will drop down to LOW, after an additional half an hour it will drop down to ECON
 - HIGH Evening Wind** The air flow begins at HIGH, after half an hour it will drop down to MED, after an additional half an hour it will drop down to LOW, after an additional half an hour it will drop down to ECON
- Breeze Wind** Automatically selects wind speed randomly as you would find outdoors. The speeds are detailed as follows:
 - ECON Breeze Wind** The wind settings will fluctuate between MED, LOW and ECON in an 75 second wind cycle that repeats with ECON being the most common
 - LOW Breeze Wind** The wind settings will fluctuate between MED, LOW and ECON in an 75 second wind cycle that repeats with LOW being the most common
 - MED Breeze Wind** The wind settings will fluctuate between HIGH, MED, LOW and ECON in an 75 second wind cycle that repeats with MED being the most common
 - HIGH Breeze Wind** The wind settings will fluctuate between HIGH, MED, LOW and ECON in an 80 second wind cycle that repeats with HIGH being the most common

TILT FUNCTION

The grille of the fan can be tilted forward and backward 17 degrees. To tilt the fan grille downwards, grasp the carry handle of the fan with one hand and gently push the bottom of the fan grille towards the back of the fan until the desired angle is achieved. To tilt the fan grille upwards, grasp the carry handle of the fan with one hand and use your other hand to gently push the top of the fan grille towards the back of the fan until the desired angle is achieved.

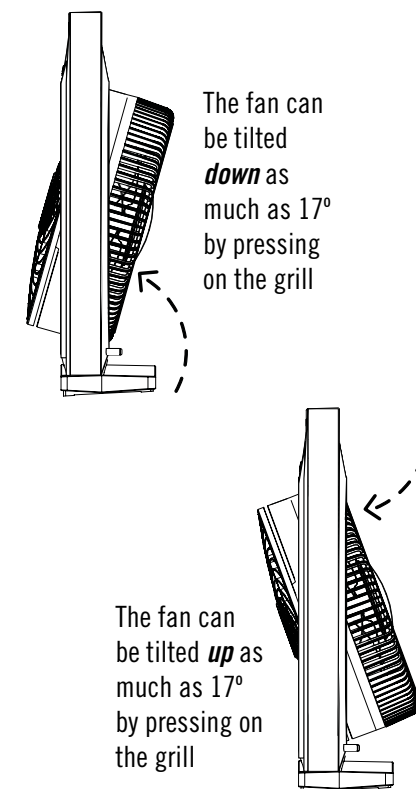

FAN CHARGING INSTRUCTIONS

1. This fan includes a wall charger to charge the fan's battery. Only use the provided charger to operate the fan and charge the fan's battery.

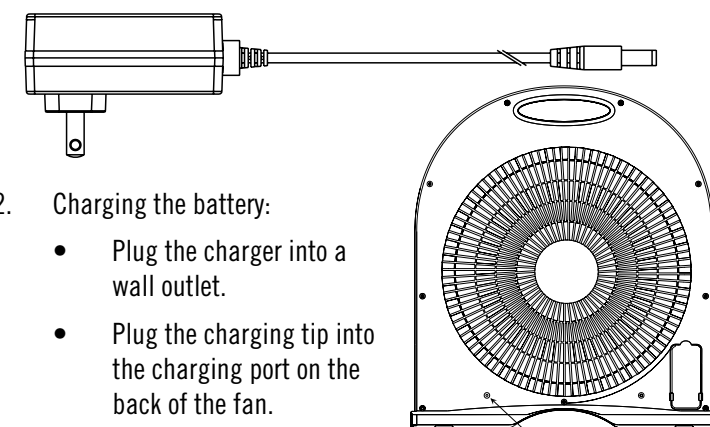

2. Charging the battery:
 - Plug the charger into a wall outlet.
 - Plug the charging tip into the charging port on the back of the fan.
 - A blinking red light will illuminate above the power button on the fan's control panel to indicate that the battery is charging. The red light will turn blue when the battery is fully charged.

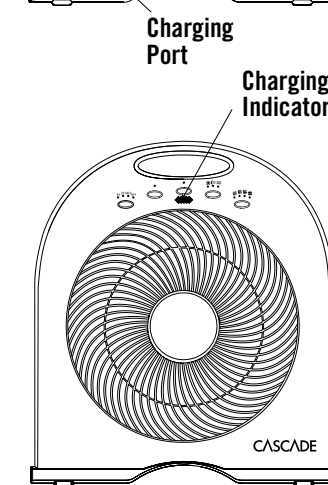

3. The fan can be used while it is charging. Using the fan while it is plugged into the charger will not prevent the battery from charging.